



AC15RM DL

Irreversible electromechanical gear motor for sliding gates.
External fitting.

Code	Leaf	Motor	Description	Pcs. Pallet
AC15RM DL	1500 Kg	230V AC	Model equipped with encoder, magnetic limit switch and control unit (RG1R DL). Electronic regulation of the motor torque. Metal gear wheels.	36

Irreversible electromechanical gear motor for sliding gates. External fitting.

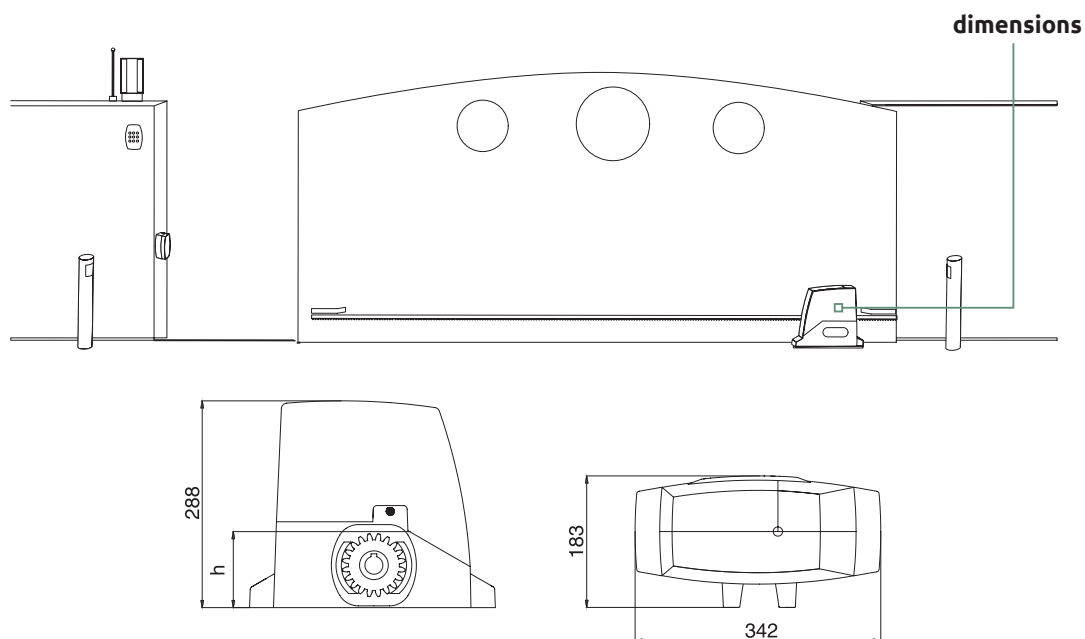

AC15RM DL

Technical specifications



	AC15RM DL
Max. gate leaf weight (Kg)	1500
Motor power supply (V)	230V AC
Power absorbed (W)	400
Thrust (N)	1500
Lubrication (Type)	Oil
Overheating protection (°C)	140
Operating T° (°C Min/Max.)	- 20 +70
Protection class (IP)	55
Speed (m/min)	8
Work intermittence (%)	50
Pinion height - h (mm)	95

AAC3



M4 Rack, 30x12x1000 galvanised and notched steel, complete with screws and spacers (4 Metres/Pack or multiple packs)

TL

- Page 116



Sign plate

