



ARMOR

Irreversible electromechanical gear motor with jointed arm for swing gates.

● = 24V DC

Code	Leaf	Motor	Description	Pcs. / Pallet
● ARO 24 UNI	2.50 m	24V DC	Irreversible gear motor. Model equipped with mechanical stop for opening and closing. Control unit not fitted on board.	24
● AR2 24P UNI DL	2.50 m	24V DC	Irreversible gear motor. Model equipped with mechanical stop for opening and closing. Control unit (RG UNI 24R DL2) for double or single motor with built-in 433.92 MHz LIFE radio receiver on board.	24

NB. We advise using ARMAX on heavy or maximum length gate leaves.

Irreversible electromechanical gear motor with jointed arm for swing gates. External fitting.

dimensions

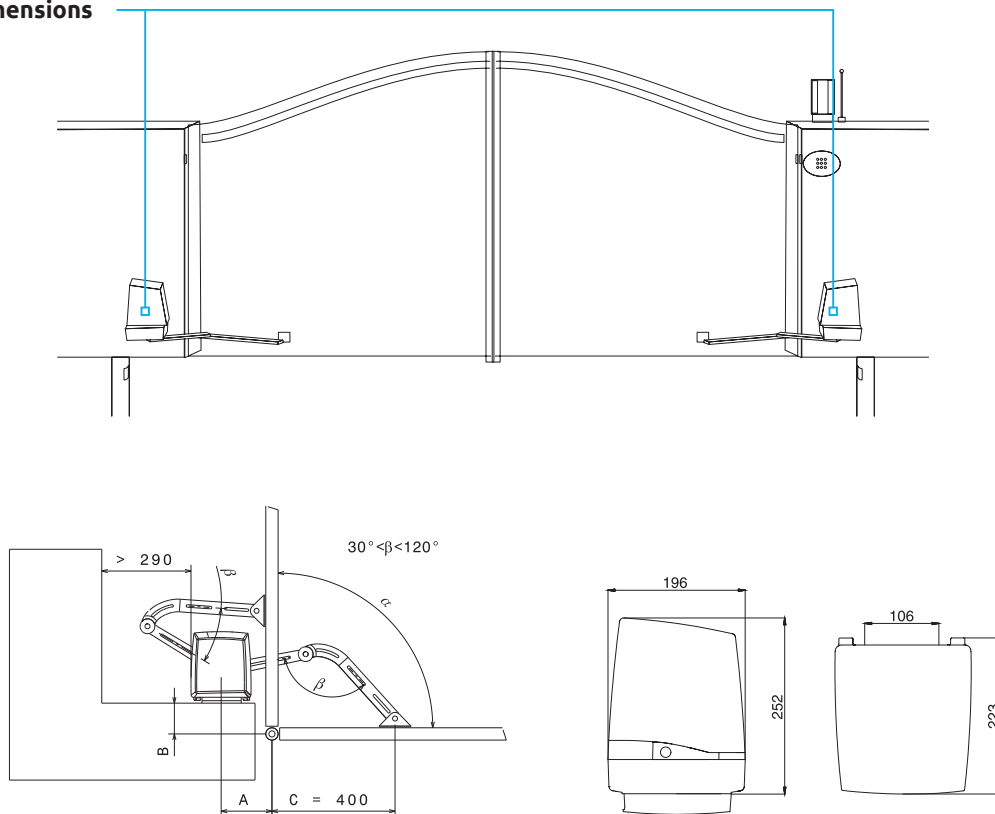

NB. Angle β to be kept between 30° and 120° to achieve optimum release; otherwise consider using the ARMAX arm

ARMOR

Technical specifications

24V



● = 24V DC

	ARO 24 UNI	AR2 24P UNI DL
Max. gate leaf length (m) - see drawing	2.50	2.50
Mains power supply (V)	230V 50 Hz	230V 50 Hz
Motor power supply (V)	24V DC	24V DC
Power (W)	40	40
Torque (Nm)	170	170
Operating T° (°C Min/Max)	- 20 + 70	- 20 + 70
Protection class (IP)	44	44
Work intermittence (%)	80	80
Time to cover 90° (s)	14	14

Limit on use

ARMOR

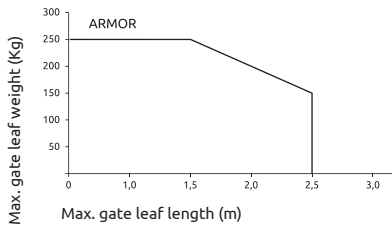

NB. In windy areas or when the gate has a particular structural shape, we advise reducing the limits on use and installing an electric lock. One should consider using ARMAX, the larger-sized jointed arm, with panelled leaves.

ARMAX



Larger-sized jointed arm (1 Pc./Pack)

ASECAR



External releasing device with metal wire (1 Pc./Pack)

DOS



Key switch with release mechanism for metal wire (1 Pc./Pack)

AELVE



Vertical electric lock (1 Pc./Pack)

AELOR



Horizontal electric lock (1 Pc./Pack)

AGECH2



Supplementary circuit for charging battery on control units (1 Pc./Pack)

AGE 12



Battery 12V - 2.3 Ah (2 Pcs./Pack)

TL

- Page 116



Sign plate