



# PROBO XL

Irreversible electromechanical gear motor with pull mechanism for sectional and up-and-over doors.

● = 24V DC

Code	Max Door Surface Area	Motor	Description	Pcs. / Pallet
● PR100 XL	12 sq.m	24V DC	Irreversible gear motor with maximum force of 900 N, equipped with an encoder. Control unit RG1 24DL with built-in 433.92 MHz LIFE radio receiver. <b>Two-channel transmitters included.</b>	50
● PR120 XL	16 sq.m	24V DC	Irreversible gear motor with maximum force of 1200 N, equipped with an encoder. Control unit RG1 24DL with built-in 433.92 MHz LIFE radio receiver. <b>Two-channel transmitters included.</b>	50

Irreversible electromechanical gear motor with pull mechanism for sectional and up-and-over doors.

dimensions

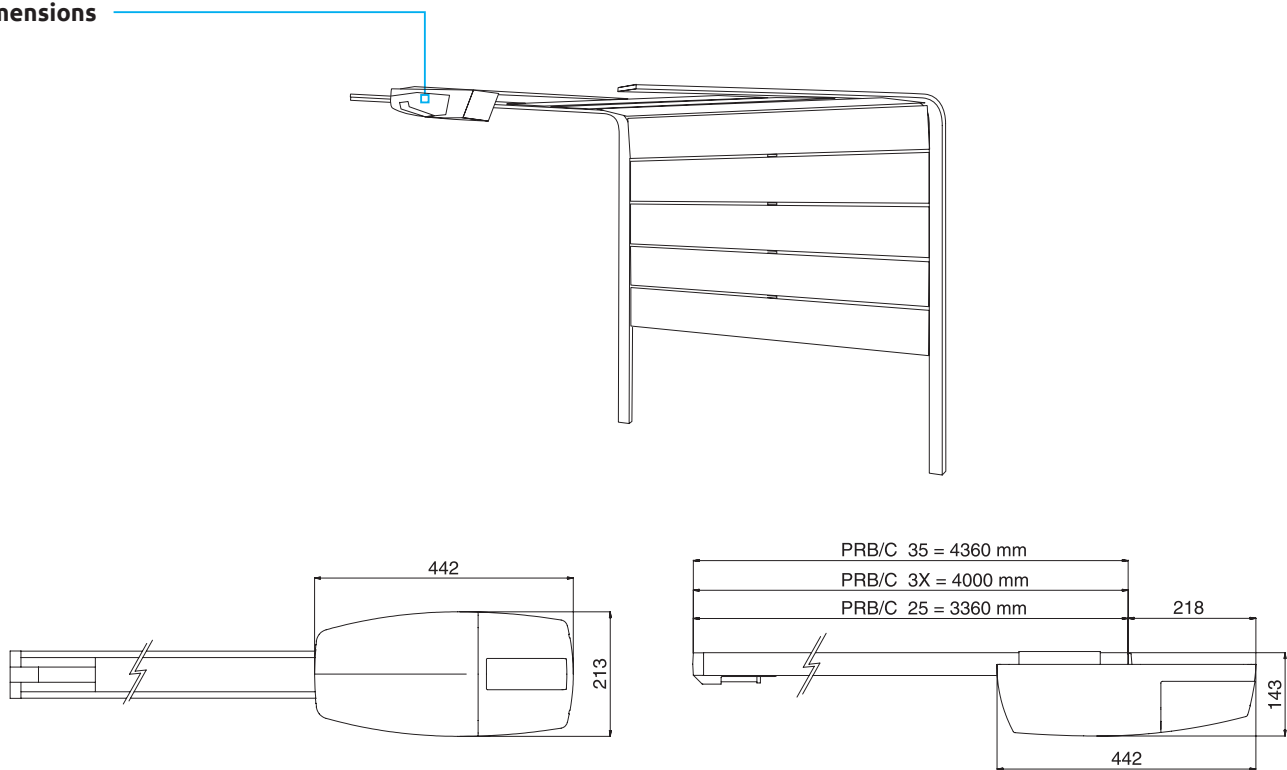

Guide rail complete with two fixing brackets and straight arm. Belt or chain transmission.

Code	Transmission	Segments	Max. Height capacity
PRB25-08	BELT	2	2.5 m
PRB3X-08	BELT	1	3.0 m
PRC25-08	CHAIN	2	2.5 m
PRC35-08	CHAIN	3	3.5 m
PRC3X-08	CHAIN	1	3.0 m

PRB BELT

PRC CHAIN



# PROBO XL

## Technical specifications

24V



● = 24V DC

	PR100 XL	PR120 XL
Max. door surface area (sq.m)	12	16
Mains power supply (V)	230V 50 Hz	230V 50 Hz
Motor power supply (V)	24	24
Power (W)	80	100
Max Force (N)	900	1200
Operating T° (°C Min/Max)	- 20 + 70	- 20 + 70
Protection class (IP)	40	40
Work intermittence (%)	50	50

### APRB



Curved swing arm running on rollers for protruding up-and-over doors (1 Pc./Pack)

### APRSK



Supplementary fixing brackets kit (1 Kit/Pack)

### PRC12



Extension of 1250 mm for PRC guide rail. Kit complete with connection, chain piece and joining chain link. (1 Kit/Pack)

### ASEC



Kit for release handle (1 Kit/Pack)

### AGECH



Supplementary circuit for charging battery on control units (1 Pc./Pack)

### AGE 12



Battery 12V - 2.3 Ah (2 Pcs./Pack)

